

# SK

## SK Series Pneumatic Percussion Hammer



### Feature

The main characteristics are: magnetic impact of large powder falling effect; air consumption, low operating cost, energy-saving effect is good; percussion interval adjustable; quality, reliable, low failure rate; structure is simple, easy removal; innovative designs, chic; piston impact resistance, (can be customized explosion proof). Widely used in pesticides, pharmaceuticals, chemicals, cement, dyes, pigments, food, electronics, building materials, mining, environmental protection and other industries, is powerful powder processing line auxiliary equipment.

### ● Overall Dimension

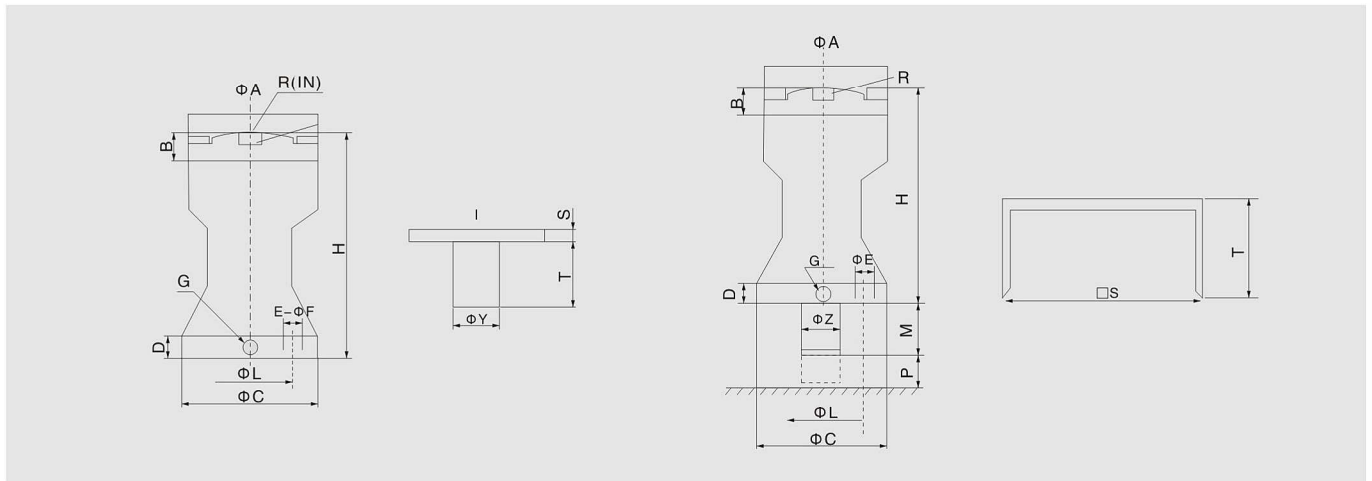

### ● Technical parameters

| Type   | A   | B  | C   | D  | E  | G   | H   | L   | S  | T  | Y  | R   |
|--------|-----|----|-----|----|----|-----|-----|-----|----|----|----|-----|
| SK-30  | 75  | 10 | 82  | 13 | 9  | 1/8 | 132 | 68  | 6  | 50 | 27 | 1/4 |
| SK-40  | 90  | 12 | 97  | 18 | 11 | 1/4 | 162 | 78  | 10 | 60 | 34 | 1/4 |
| SK-60  | 121 | 13 | 143 | 19 | 15 | 1/4 | 215 | 100 | 10 | 60 | 48 | 1/4 |
| SK-80  | 160 | 17 | 170 | 20 | 17 | 3/8 | 260 | 140 | 14 | 90 | 70 | 3/8 |
| SK-100 | 200 | 18 | 200 | 23 | 17 | 3/8 | 318 | 160 | 18 | 90 | 70 | 3/8 |

| Type   | Operating pressure (kgf/cm <sup>2</sup> ) | Air consumption L | Wallop kgm/sec | Weight kg |
|--------|---|-------------------|----------------|-----------|
| SK-30  | 3~7                                       | 0.028             | ~0.75          | 1.1       |
| SK-40  | 3~7                                       | 0.082             | ~2.2           | 2.2       |
| SK-60  | 3~7                                       | 0.228             | ~7.4           | 5.1       |
| SK-80  | 4~5                                       | 0.455             | ~16.4          | 11.1      |
| SK-100 | 5~7                                       | 1.012             | ~30.0          | 37.5      |